

Features

Series:	T
Type:	20
Code:	07.225.067.11
Description:	T201010ENC12C12
Customer's code:	-
Colour:	Black

Last drawing

Index:	-	Date:	-
--------	---	-------	---

Application

-

Driveline data

X	1 3/8" Z6 DIN 9611
Y	1 3/8" Z6 DIN 9611
E	885-34.84"
I	900-35.43"
P	820-32.28"

Overlap

	Steel tubes	Guard
Max.	865-34.06"	800-31.5"
Min.	281-11.06"	216-8.5"

Greasing point

1)	-
2)	-

The dimensioning is cross to cross

Cross and tubes

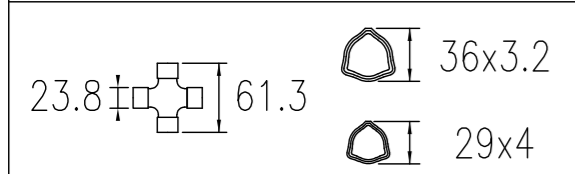

End fittings	Max. torque
Tractor Cod: C12	-
Implement Cod: C12	-

Notes:
 CERTIFIED

Warning !
 Sections of driveline marked are not shielded and must be shielded by an interactive guarding system.
 COMER spa declines responsibility if proper guards are not provided or maintained.

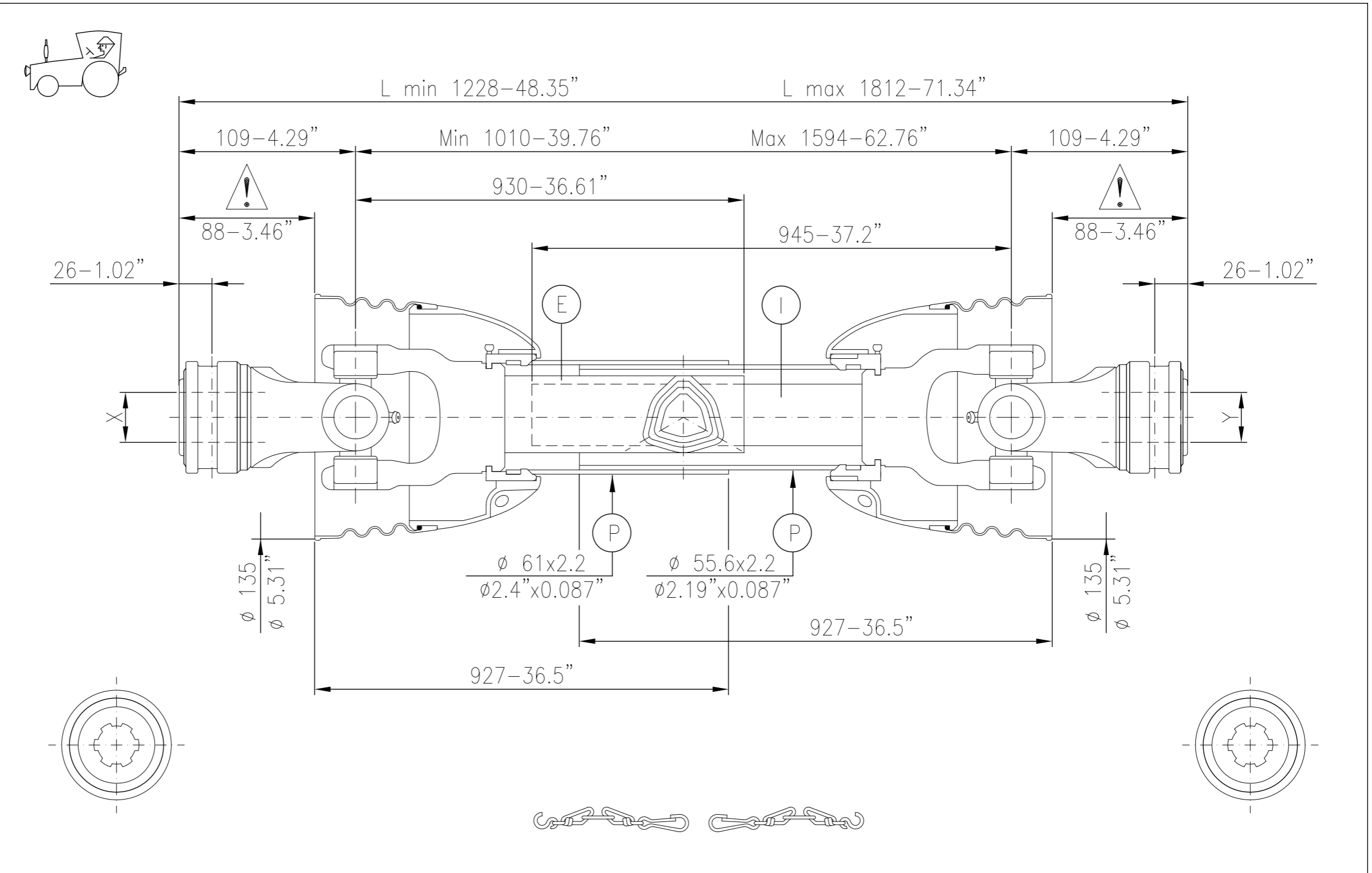

Data 540 r.p.m.			
KW	CV	Nm.	in.lb.
15	21	270	2400

Data 1000 r.p.m.			
KW	CV	Nm.	in.lb.
23	31	220	1950

1100 min.⁻¹
 r.p.m. max.

Data for only critical velocity	
540 r.p.m.	1000 r.p.m.
Max. -	Max. -
L max. -	L max. -
Checked:	Signed by: A.S.

Customer:

 Date: 31-10-17

Continuous operation data and conditions, working angle 5°, average life 1000 hours